

普通表径向直接安装 (Y-1.5"、2"、2.5"、3.5"、4"、4.5"、5")

普通表外形尺寸

MODEL	D (∅)	d	L	B	H	H ₁
Y-1.5"(40)	42	NPT 1/8	10	34	23	8
Y-1.5"Z	42	NPT 1/8	10	41	25	
Y-2"(50)	52.5	NPT 1/4	12	46	28	10
Y-2"Z	52.5	NPT 1/4	12	48	28	
Y-2.5"(63)	63.5	NPT 1/4	12	50	28	11
Y-2.5"Z	63.5	NPT 1/4	12	48	29	
Y-2.85"Z	72.5	NPT 1/4	12	52	31	
Y-3.5"(89)	89	NPT 1/4	12	69	30	11
Y-3.5"Z	89	NPT 1/4	12	51	30	
Y-4"(100)	100	NPT 1/4	12	80	34	13
Y-4.5"(115)	114.5	NPT 1/4	13	80	35	12
Y-4.5"Z	114	NPT 1/4	13	55	34	
Y-5"(125)	125.5	NPT 1/4	13	87	29	10

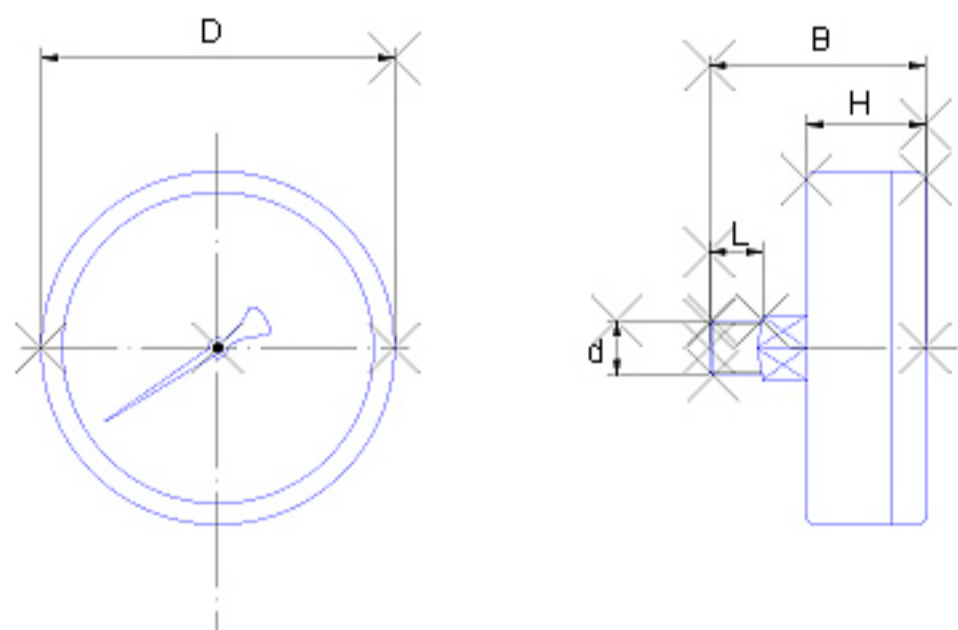

普通表轴向直接安装 (Y-1.5"Z、2"Z、2.5"Z、2.85"Z、3.5"Z、4.5"Z)

普通表外形尺寸

MODEL	D (∅)	d	L	B	H	H ₁
Y-1.5"(40)	42	NPT 1/8	10	34	23	8
Y-1.5"Z	42	NPT 1/8	10	41	25	
Y-2"(50)	52.5	NPT 1/4	12	46	28	10
Y-2"Z	52.5	NPT 1/4	12	48	28	
Y-2.5"(63)	63.5	NPT 1/4	12	50	28	11
Y-2.5"Z	63.5	NPT 1/4	12	48	29	
Y-2.85"Z	72.5	NPT 1/4	12	52	31	
Y-3.5"(89)	89	NPT 1/4	12	69	30	11
Y-3.5"Z	89	NPT 1/4	12	51	30	
Y-4"(100)	100	NPT 1/4	12	80	34	13
Y-4.5"(115)	114.5	NPT 1/4	13	80	35	12
Y-4.5"Z	114	NPT 1/4	13	55	34	
Y-5"(125)	125.5	NPT 1/4	13	87	29	10